

eaZI®flex VITROX 100

PENDULUM HINGE GLASS-WALL CONNECTION

ORIGIN: RHEINAU, GERMANY

TYPE: EAZI®FLEX

SERIES: VITROX 100

MEDIUM: FLUID

HINGE TYPE: SWING DOOR HINGE

ART.-NO.: H010-00-001

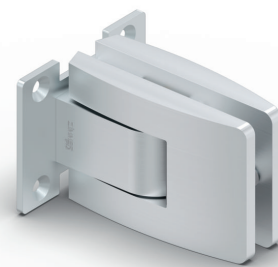
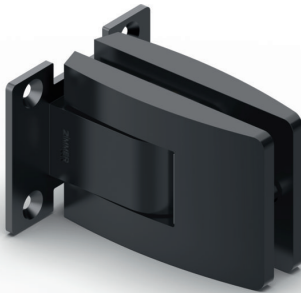

The eaZI®flex VITROX 100 swing hinge is the perfect embodiment of elegant convenience. This innovative swing door hinge is installed as a connecting piece between a fixed part and a glass or wooden door and offers impressive functionality.

Innovative technology and versatility

With the eaZI®flex VITROX 100 pivot hinge, it is possible to open the door both inwards and outwards, up to an angle of 90 degrees. This double-sided opening allows the door to be used *flexibly* in a wide variety of rooms and situations. A particular highlight is the ability to lock the door in any position, which offers additional convenience and *flexibility*.

Automatic and soft closing

Another advantage of the eaZI®flex VITROX 100 is its ability to close automatically from a door position of 70 degrees. Closing is particularly gentle and quiet thanks to the integrated soft-close technology. This ensures that the door moves quietly and centred into the closed position, which is not only functional but also aesthetically pleasing.

Elegant design

The pendulum hinge impresses with its elegant design. The smooth surface gives the hinge a pleasant feel and a visually appealing appearance. With its slim shape and rounded edges, the eaZI®flex VITROX 100 blends harmoniously into the design of any door without being obtrusive. It combines form and function in a way that is both visually and practically appealing.

Comfortable handling

The ease of use of the eaZI®flex VITROX 100 is outstanding. A gentle pull on the open door is all it takes to close it gently and quietly. The door rotates effortlessly to the centre and centres itself automatically, which makes handling the door much easier and at the same time conveys a feeling of high quality.

Highest quality from German production

Quality is a top priority at eaZI®flex VITROX 100. All hinges are manufactured in our production facility in Germany, with every single product undergoing 100% quality testing. These rigorous tests ensure that every pendulum hinge meets the highest standards and guarantees consistently high product quality.

The eaZI®flex VITROX 100 pivot hinge is the ideal choice for your glass and wooden doors. It combines elegant design with maximum convenience and excellent quality, making it an outstanding solution for modern living and working spaces!

Our products are 100% tested

Our products are checked with a camera during production. The use of industrial image processing enables 100% inspection of critical geometric product features and ensures consistent quality.

CO₂-neutral power generation: Regional and green

The Zimmer Group obtains all of its electricity from CO₂-neutral sources. Part of this energy comes from a regional power plant, while the majority is generated by our own photovoltaic systems. The expansion work for additional photovoltaic modules is in full swing.

TECHNICAL DATA

Technology:	Defined Comfort
Limited use:	no
Field of application:	10-40 °C
Extended operation area:	no
Hinge type:	Swing door hinge
Load capacity per hinge:	35 kg
Damping:	Adjustable
Closure from:	70 °
Length:	127 mm
Width:	100 mm
Height:	82 mm
Fastening type on door side:	Clampable
Mounting type On-site:	Screwable
Opening direction:	Double-sided
Opening angle:	90 °
Adjustable zero position :	yes
Setting range:	5 °
Door thickness:	8-13.5 mm
Type of glass:	ESG/VSG

MATERIAL

Housing material:	Zinc die casting
Housing color:	black matt RAL9005
Housing surface:	powder-coated

TEST METHOD

Lifetime :	500,000 Cycles
Standard 1:	DIN EN 1154:2003
Standard 2:	DIN EN 1670:2207
Overload test:	10 x 1 m/s
Endurance test:	500.000 Zyklen 0,25m/s

GENERAL DATA

Logo:	Zimmer
Carton, PU:	1 Piece
Cardboard, weight:	2.3 kg
Cardboard, width:	100 mm
Cardboard, length:	60 mm
Cardboard, height:	100 mm

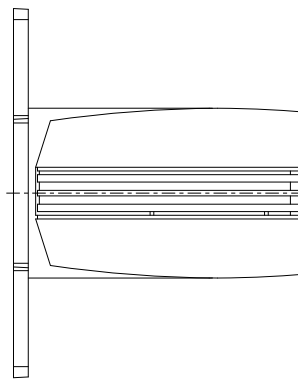
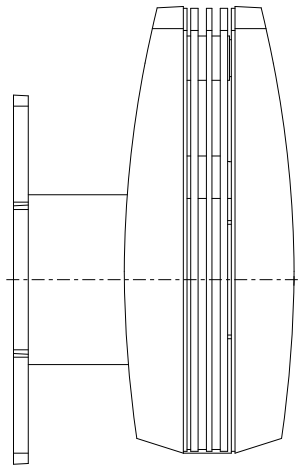

rotation +90°

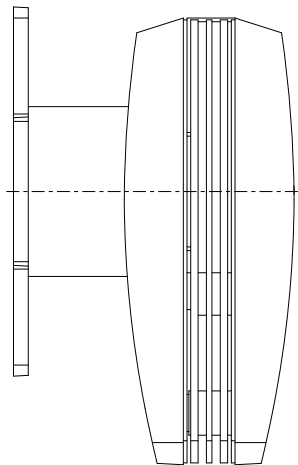

rotation -90°

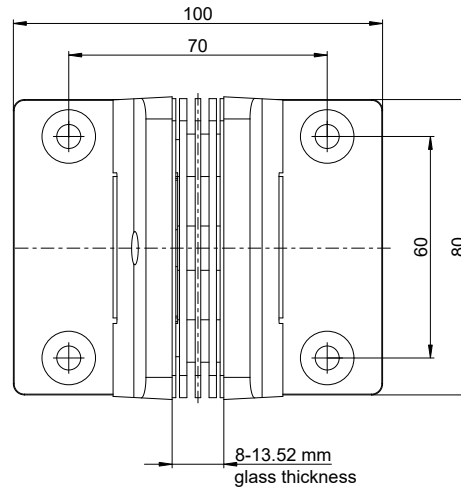

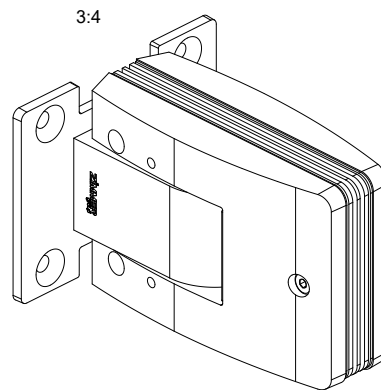
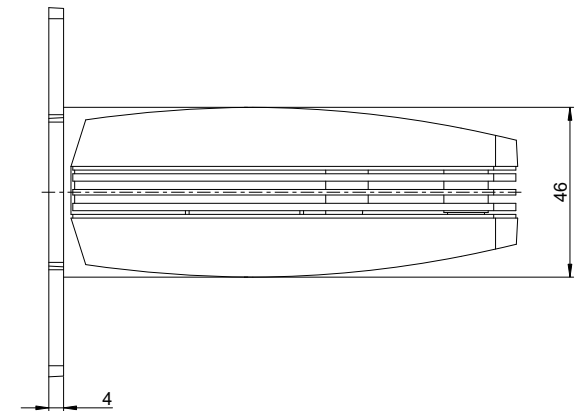
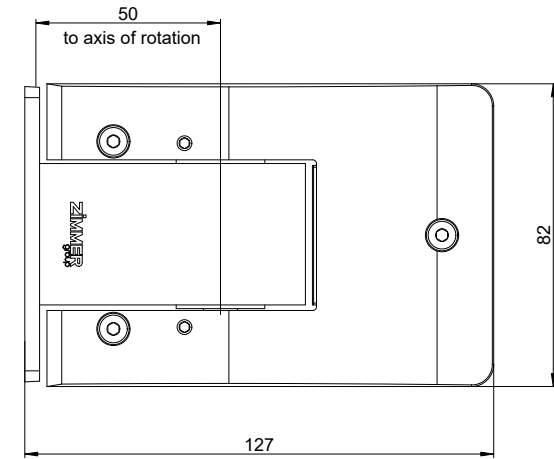

8-13.52 mm
glass thickness



3:4

Color: black matt

		Allgemeintoleranzen/ standard tolerances ISO 2768:1989 T1-m/T2-K		Maßstab scale 1:1	Oberfl. surface 212056mm ²	Gewicht weight 2.0907kg
Vertriebsart, auch bei Änderungen, nur mit schriftlicher Genehmigung der Zimmer Group. Reproduction, copying, even in extracts, only with the written approval of Zimmer Group.		Datum/Date 29.08.24	Name/Name Izesch	Werkstoff/ material -	Volumen/ volume 318212mm ³	DREHTUER
Kanten nach/Edges according to ISO 13715		checked 30.08.24	akraus	Halbausg. dimension -	Spalte class -	Zeichnungsnummer/drawing number H010-00-001_c
c. Anpassung Änderung/modification	29.08.24 Izesch	Zimmer GmbH Dampfungssysteme		dev. 08.05.24 akraus	Freigabestatus/Status: Zind_60	Blatt/sheet 5 v. 5 Bl.
projection				eaZiflex VITROX 100 Wandbefestigung		