

PRODUCT INFORMATION

eaZiflex VITROX 200

GENERAL DATA:

Type of product: SOFT CLOSE swing door hinge

Origin: Rheinau, Baden-Württemberg, Germany

Lifetime: 500.000 cycles

Installation option: Glass door > glas-to-glas-connection

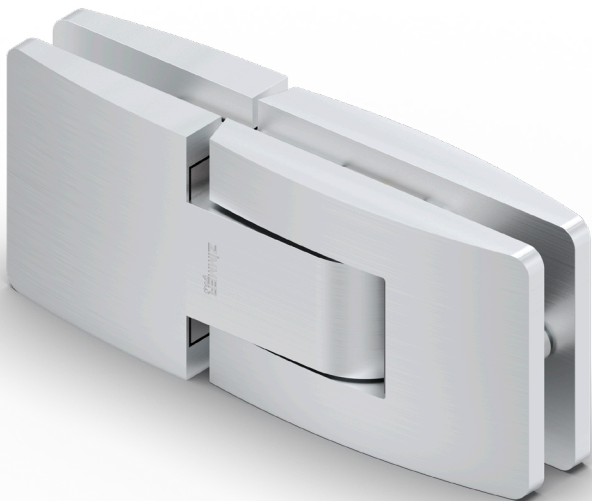

The new innovative SOFT CLOSE swing door hinge is installed as a connecting piece between a fixed part and a glass door.

FUNCTION

Hinge at 0° (door closed)

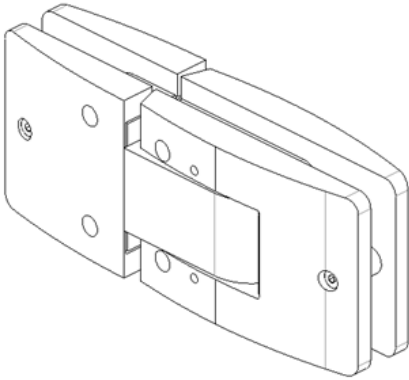

Hinge at +90° (door open)

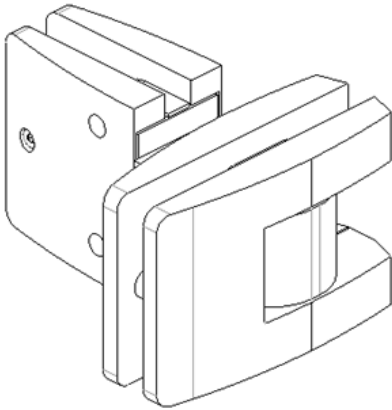

Hinge at -90° (door open)

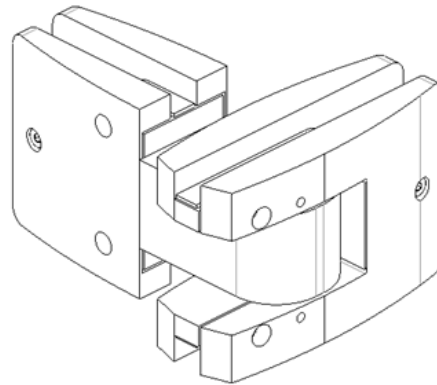

GLASS CONNECTION

The glass is inserted into the space inside the hinge (blue arrow) and then clamped with screws (black arrows):

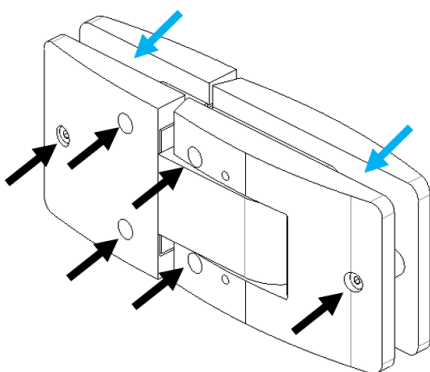

This is how the glass door is connected to the hinge.

TECHNICAL DATA

Length [mm]:	199
Width [mm]:	46
Height [mm]	82
Load capacity per hinge [kg]:	35
Lifetime [cycles]:	500.000
Operating conditions [°C]:	10 to 40
Storage conditions [°C]:	-20 to 80

GLASS PREPARATION

Door

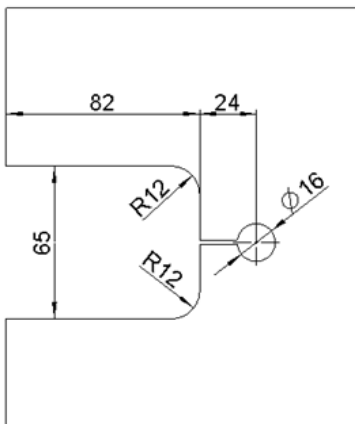

Fixed glass

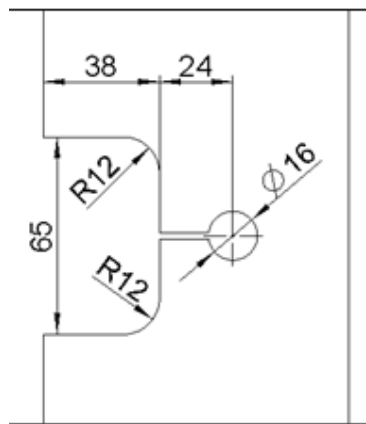

CHARACTERISTICS

- ▶ Opens 90° on both sides
- ▶ Locking when the door is open
- ▶ Automatic closing from an opening angle of 70°
- ▶ Automatic closing and centering to 0°
- ▶ Zero-position with spring preload
- ▶ Adjustable zero-position (zero position means the position of the closed door. It can compensate tolerances)
- ▶ Glass thickness: 8 mm | 10 mm | 10,76 - 11,52 mm | 12 mm | 12,76 - 13,52 mm
- ▶ Opening of the door beyond 90° must be limited with a stopper

TEST PROCEDURE

The hinge is tested on the basis of:

- ▶ DIN EN 1154:2003
- ▶ DIN EN 1670:2007

TECHNICAL DRAWING

