

Product information

Silento Doppio 70

**THE
KNOW-
HOW
FACTORY**

ZIMMER GROUP

Am Glockenloch 2
77866 Rheinau
T +49 7844 9110-0
info@daempfungssysteme.de
www.zimmer-group.com
www.zimmer-softclose.shop

General data:

Type of product:	Self-closing unit with fluid damper
Origin:	Rheinau, Baden- Württemberg, Germany
Lifetime:	100.000 cycles
Installation option:	Sliding door Drawer

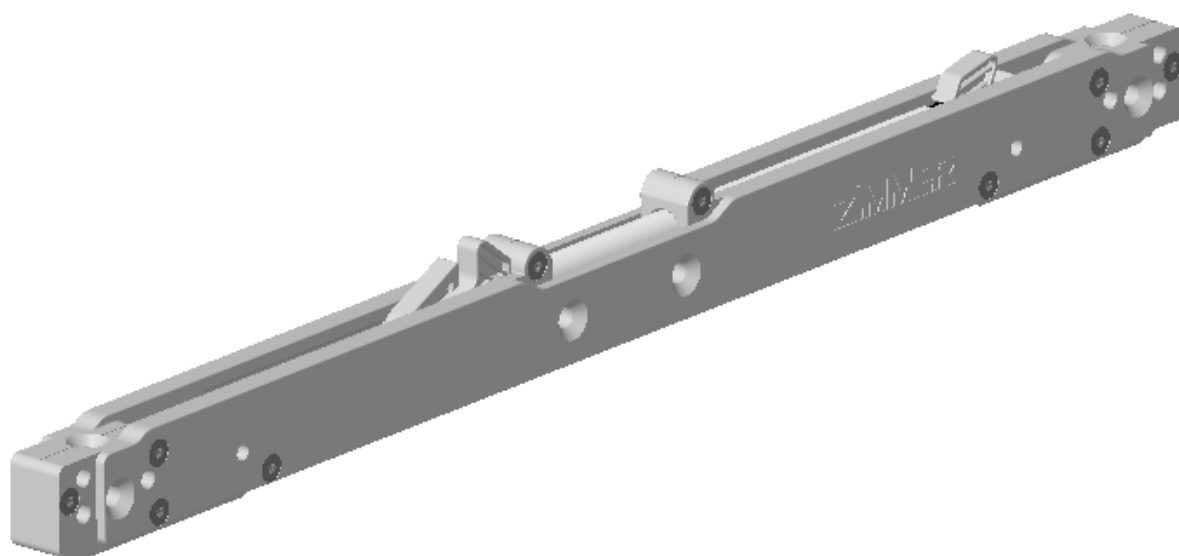

Customer-friendly, uncomplicated and extremely diverse.

The Silento Doppio offers a pleasant damping of sliding doors in both directions - opening and closing. User-friendly connection options complete the new ZIMMER product: Whether invisibly integrated into an existing track, mounted in various installation positions (flat, upright, right or left-hand locking) or adaptively mounted on the carriage.

Index

1. Content	3
2. Function.....	3
3. Technical data	4
4. Characteristics	4
5. Integration	5
6. Positioning in a rail	6
7. Overlap of locking hooks	7
8. Accessory.....	8
9. Damping characteristic.....	9
10. Technical drawing	10
11. Test procedure.....	11
12. Materials.....	11

1. Content

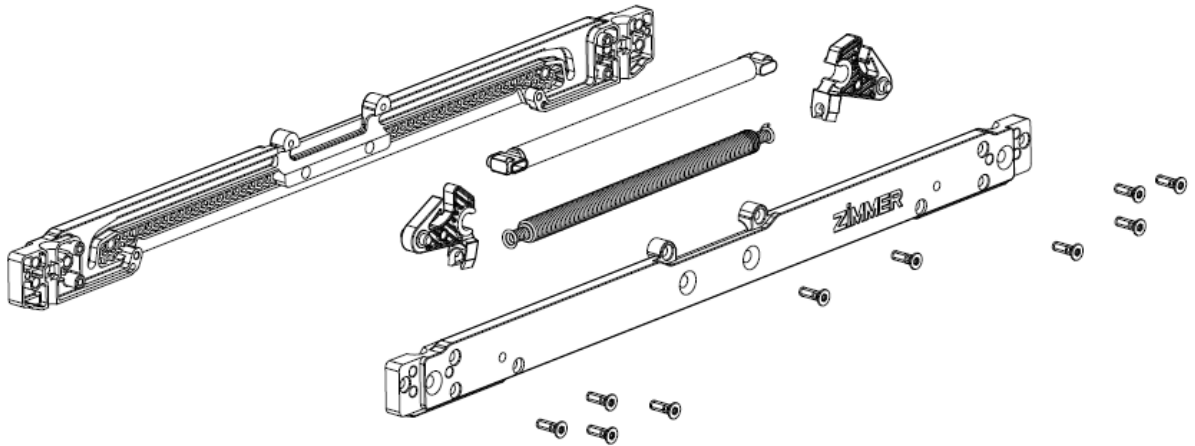

2. Function

One side is always in the end position the other side is pulled open when the element is opened. Thus, the unit is charged. Now it can dampen both in the front end position and in the rear end position.

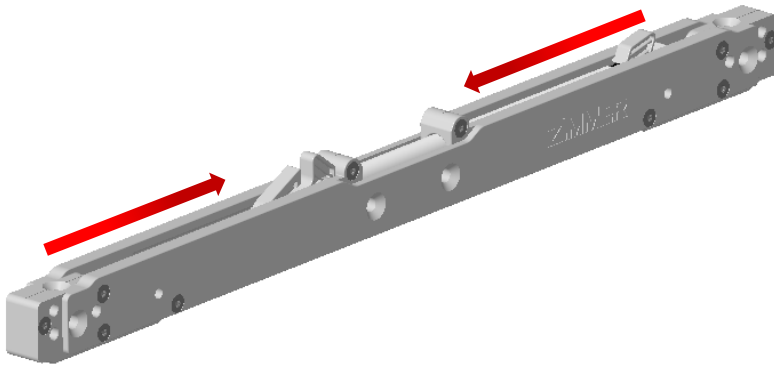

3. Technical data

Housing length [mm]:	318
Housing width [mm]:	16,4
Housing height (total height) [mm]:	26,9 (31,6)
Distance fixing points [mm]:	320
Ø of fixing holes [mm]:	4,2 / M4
Stroke [mm]:	70
Weight to be braked [kg]:	15-120
Lifetime [cycles]:	100.000
Release:	possible
Operating conditions [°C]	+10 <-> +40
Storage conditions [°C]	-20 <-> +80

4. Characteristics

Closed unit	
Effective direction outside closing	
Effective direction inside closing	<input checked="" type="checkbox"/>
Fluid damper	<input checked="" type="checkbox"/>
Air-friction damper	
Damping effect one-way	
Damping effect both-sided	<input checked="" type="checkbox"/>
Different locking hooks possible	<input checked="" type="checkbox"/>
Emergency function	<input checked="" type="checkbox"/>

5. Integration

Main application:

Sliding door	<input checked="" type="checkbox"/>
Drawer	
Hinge	
Flap	

Für Einzugseinheit:

Multiple orientation of the fixing possible	<input checked="" type="checkbox"/>
Fixing hole with lowering	<input checked="" type="checkbox"/>
Connection to running gear provided	<input checked="" type="checkbox"/>
Mounting on running rail possible	<input checked="" type="checkbox"/>
Retrofit	<input checked="" type="checkbox"/>
Threaded nut possible for the fixation	<input checked="" type="checkbox"/>

Do not use as end stop! Additional customer-side end stop necessary!

Possible integration:

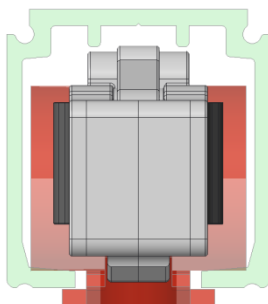
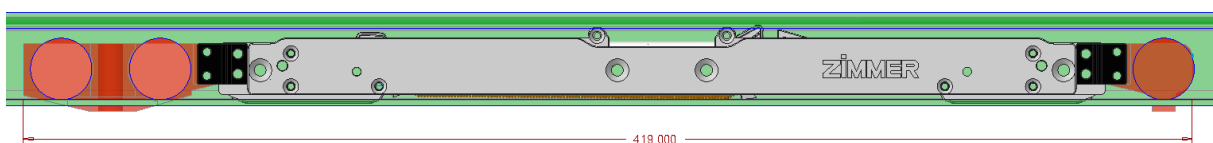

6. Positioning in a rail

The activator distance to the wall is different

Activator in the left end position

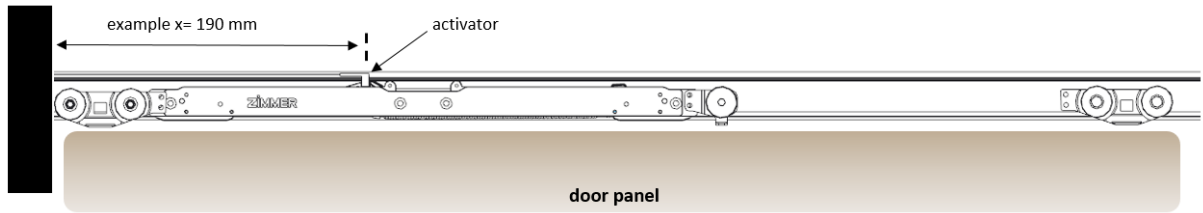

Activator in the left end position

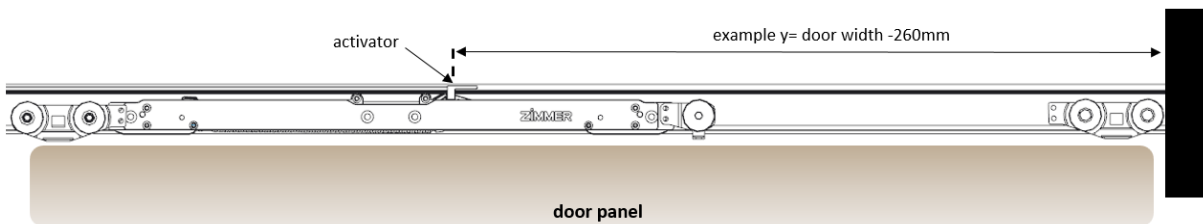

7. Overlap of locking hooks

Type S: Standard / High locking hook (5-KUN00136 / 5-KUN00137)

	Nominal dimensions [Figures in mm]	Tolerance range [Figures in mm]
A	105,60	-1,00
B	1,00	+1,00 / -0,50
C	5,00	-0,20
D	4,90	±0,10

Type B: Low locking hook 5-KUN81217)

	Nominal dimensions [Figures in mm]	Tolerance range [Figures in mm]
A	105,60	-1,00
B	0,50	-2,00
C	5,00	-0,20
D	4,90	±0,10

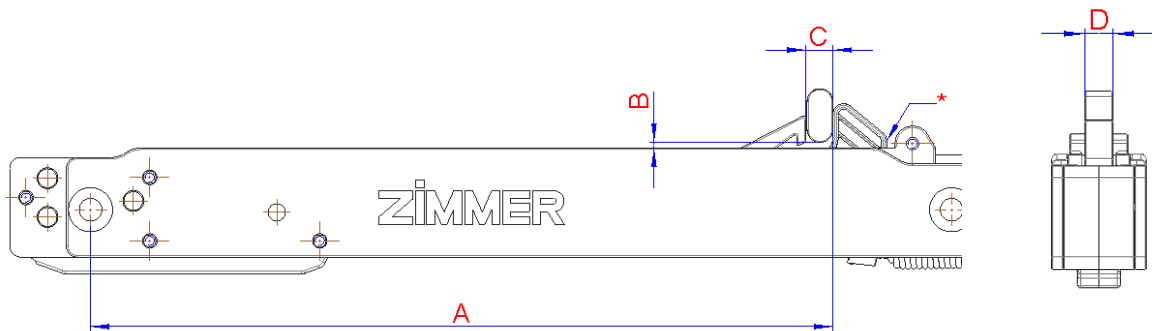

Note:

When using your own activator, make sure that dimensions A / B / C are maintained. The shape of the activator is to be determined by arrangement Fa. Zimmer.

8. Accessory

Locking hook

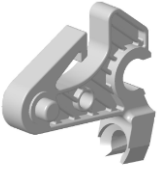
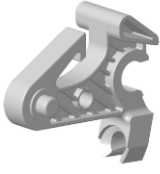
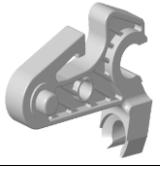
	Standard locking hook Type S
	Locking hook with wider top allows greater coverage with activator Type C
	Lower locking hook if space is tight Type B

Connection

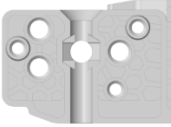
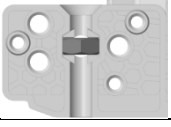
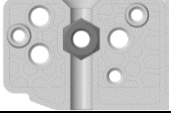
	Without slot nut
	Vertical slot nut
	Horizontal slot nut

9. Damping characteristic

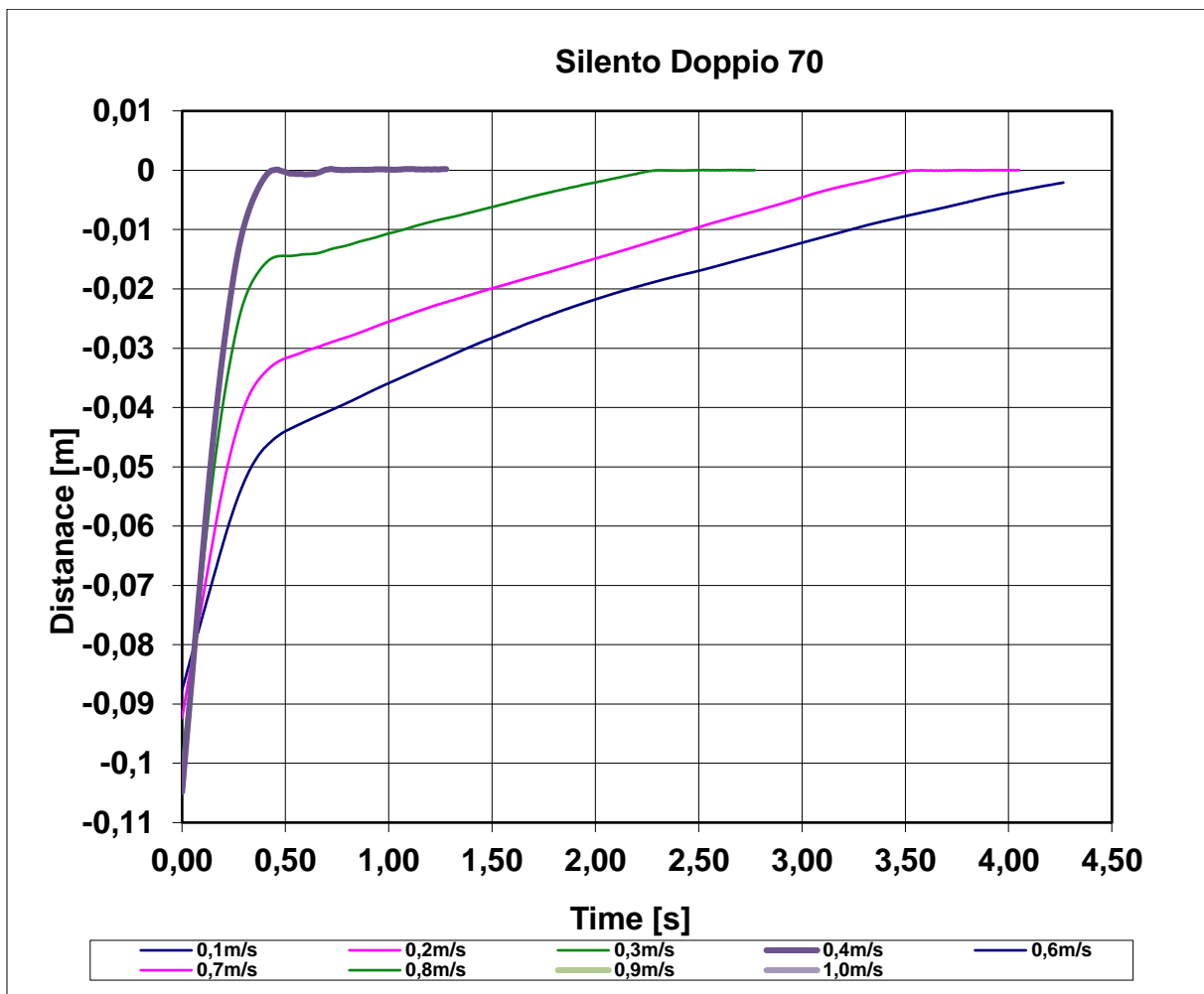

Spec.v[m/s]	v[m/s]	Wp.[mm]	Sz.[s]	Hz.[s]	Rb.[mm]	m[kg]
0,10	0,12	43,7	4,5	0,0	0,0	100,0 kg
0,20	0,20	31,7	3,5	0,0	0,0	100,0 kg
0,30	0,32	14,6	2,2	0,2	0,0	100,0 kg
0,40	0,40	0,0	0,4	0,0	0,0	100,0 kg

10. Technical drawing

Operating conditions: +10°C to +40°C
 Storage conditions: -20°C to +80°C
 Stroke: 70mm
 Max. mass to be braked: 30kg
 Do not use as end stop.

general tolerances acc. to DIN ISO 2768 - m

Material	13.20	Order	68352mm ³	Order weight	0.0862kg
Weight	-	Material	-	Volume	63707mm ³
Surface treatment	-	Surface	-	Sign	SEZFLB
Reference	Reference				
Design	16.05.18	Manufacturer	Self-closing return		
Version	12.06.18	Product	Silento Doppio 70		
Drawn	-	Part number	ZIM2436		
Checked	-	Drawing number	E070-08-050_-		

Zimmer GmbH Deutschland

Kanten nach Edges according to ISO 13715

projection

Alle Maße sind in mm angegeben! (All rights reserved)
 Verantwortung für Änderungen: nur im schriftlichen Auftrag der Zimmer Group
 Reproduktion, Kopie oder Weitergabe ist ohne schriftliche Erlaubnis der Zimmer Group.

path (mm)

time (s)

spring value without friction!

F(N)

F1 F2

L1 L2

L1=130mm
 L2=192mm
 F1=10±3N
 F2=30±5N

11. Test procedure

Test	Requirements according to Zimmer	Requirements Zimmer met
Long-term test	100.000 cycles	✓
Over stress test	10x 1 m/s	✓
Storage test	-20°C to 80°C	✓
Climate test	10°C to 40°C	✓

12. Materials

Selfclosing unit:

Housing:	PC/ABS
Hook:	POM
Spring:	EN10270-1-DH