

Product information

Piano

**THE
KNOW-
HOW
FACTORY**

ZIMMER GROUP

Am Glockenloch 2
77866 Rheinau
T +49 7844 9110-0
info@daempfungssysteme.de
www.zimmer-group.com
www.zimmer-softclose.shop

General data:

Type of product: Air friction damper
Origin : Rheinau, Baden- Württemberg, Germany
Lifetime: 100.000 cycles
Installation option: Hinge

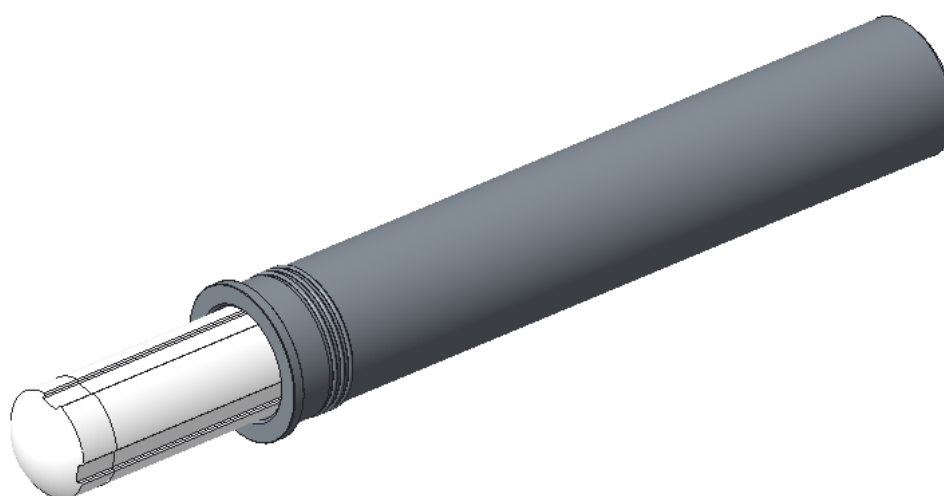
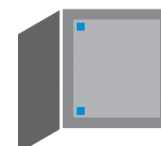

Index

1. Content.....	3
2. Function.....	3
3. Technical data	4
4. Characteristics.....	4
5. Integration	4
6. Accessories	5
7. Damper characteristic	5
8. Technical drawing.....	6
9. Test procedure	7
10. Materials.....	7

1. Content

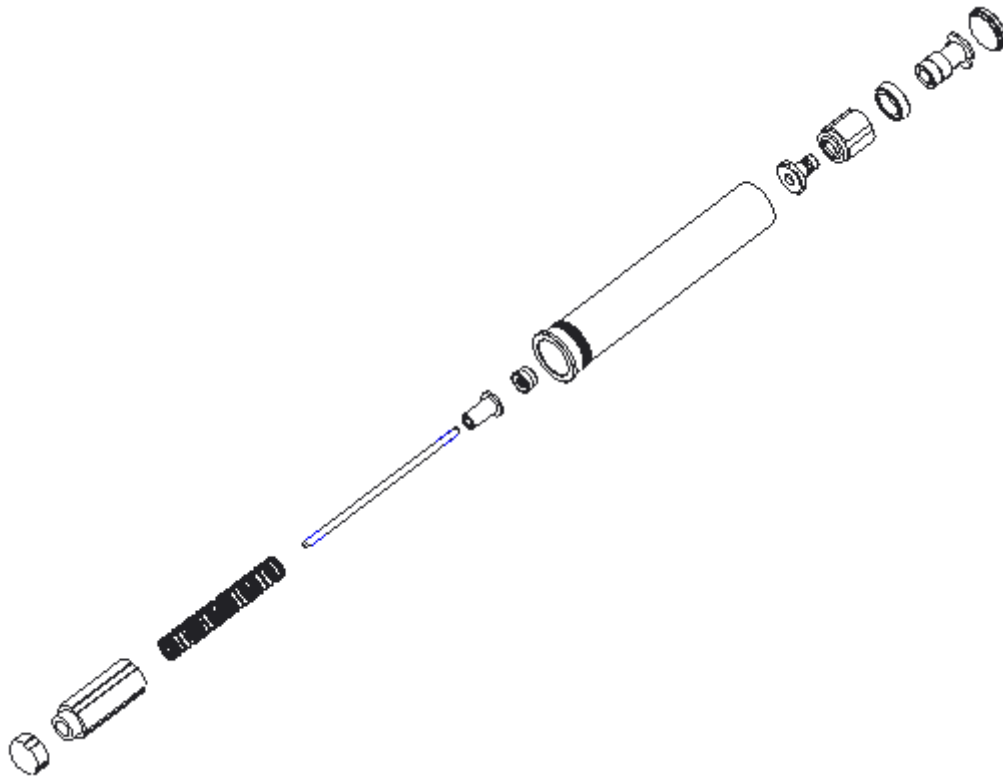

2. Function

- Air-friction damper with 19 mm stroke
- One way damping with returnspring

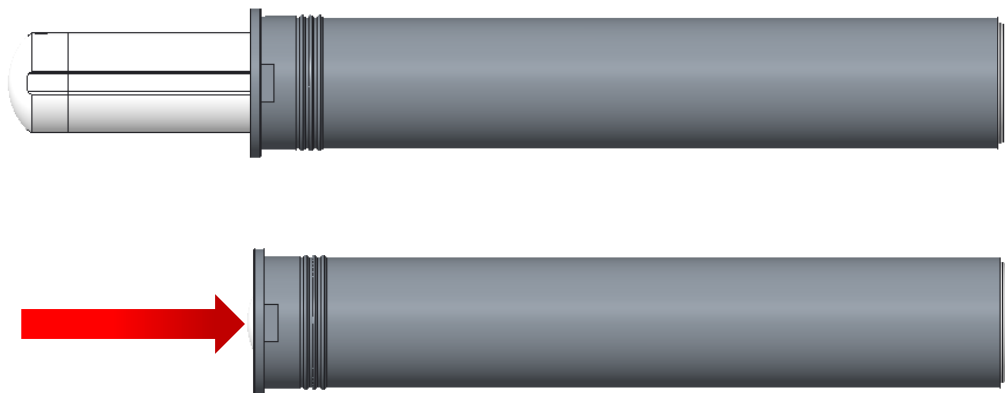

3. Technical data

Housing length [mm]:	56
Housing diameter [mm]:	9,7
Stroke [mm]:	19
Return spring	yes
Maximum weight to be braked [kg]:	6
Lifetime [cycles]:	100.000
Release:	yes
Operating conditions [°C]	10 to 40
Storage conditions [°C]	-20 to 80

4. Characteristics

Extract damper	
Push damper	<input checked="" type="checkbox"/>
Fluid damper	
Air-friction damper	<input checked="" type="checkbox"/>
Different damping characteristics	

5. Integration

Main application:

Sliding door	
Drawer	
Hinge	<input checked="" type="checkbox"/>
Flap	

6. Accessories

Connection / Coupler

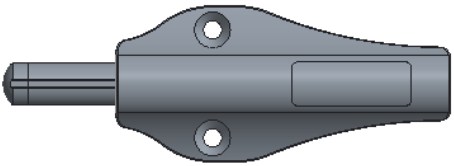
	Damper with adapter/ mounting
---	-------------------------------

7. Damper characteristic

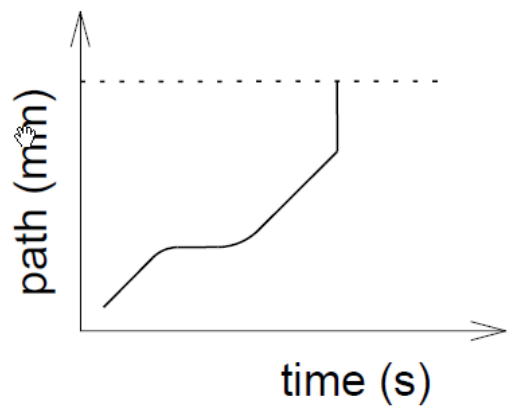

8. Technical drawing

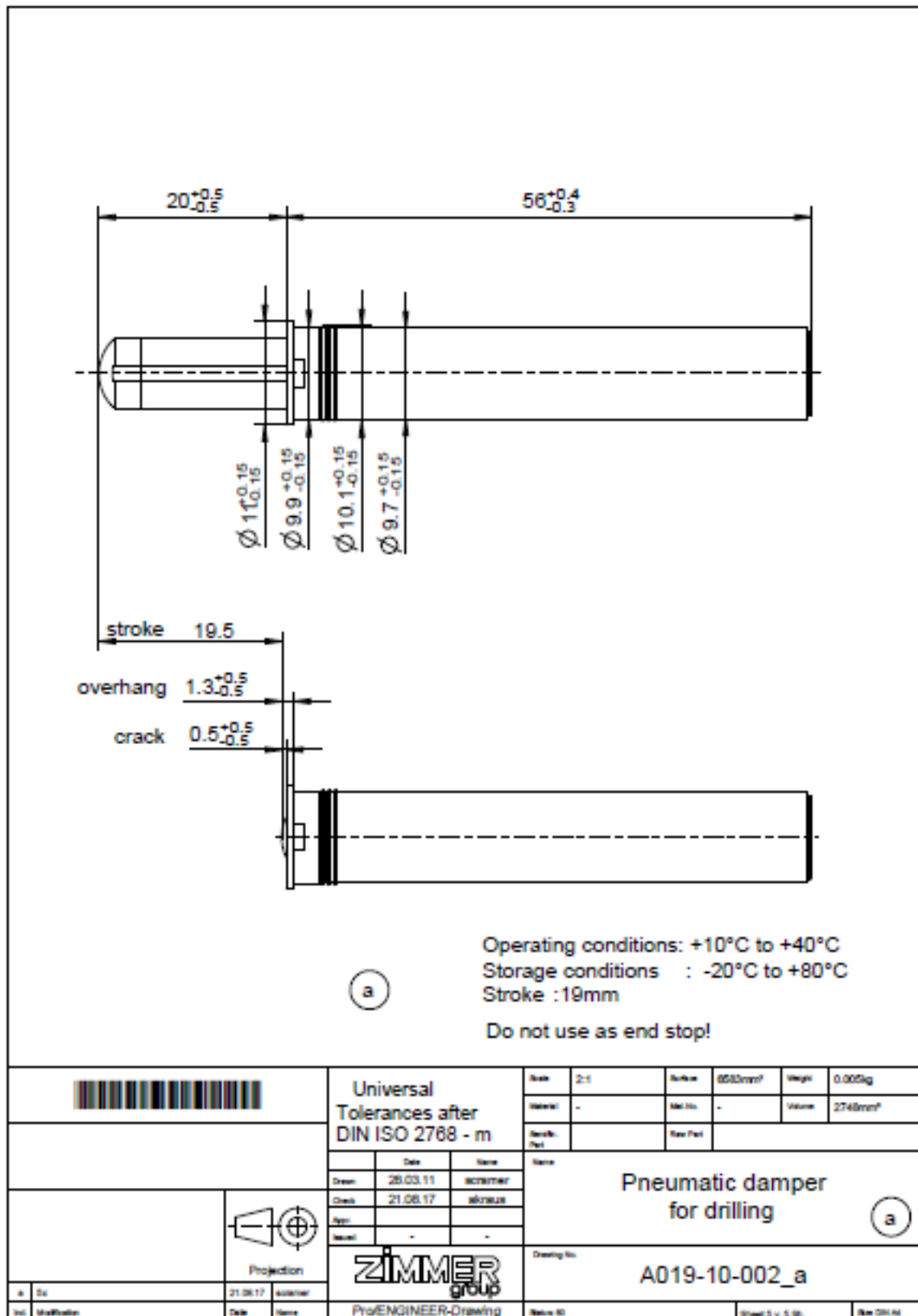

9. Test procedure

Test	Requirements according to Zimmer	Requirements Zimmer met
Long-term test	100.000 cycles	✓
Over stress test	10 x 1 m/s	✓
Storage test	-20°C to 80°C	✓
Climate test	10°C to 40°C	✓

10. Materials

Damper:

Housing:	POM
Piston rod:	X8CrNiS18-9
Sealing	NBR